

AUTOMATIC BURNER CONTROL SYSTEM

The burner control unit QBK [*cubic*] is suitable for the control of burners up to 350 kW, pursuant to EN 746-2, for intermittent or continuous operation.

Flame control by means of UV scanner or ionization rod (even shared with ignition).

Times and cycle are configurable: the same device can be used to control different types of gas and oil burners, meeting all relevant requirements.

A led-bar flame signal indicator and an advanced self-diagnostic system provides the display of either the cycle status, lockouts and failures.

Remote control and supervision of the burner can be implemented by means of communication line.



SAFETY INFORMATION

Read and understand this manual before installing, operating, or servicing this unit. This unit must be installed according to this manual and local regulations. The drawings may show units without covers or safety shields to illustrate details. Disconnect power supply and follow all usual safety precautions before carrying out any operation on the device. Be sure to reinstall covers or shields before operating any devices.

The device is not user serviceable, a faulty device must be put out of order and sent back for servicing.

CONTRIVE manufactures products used as components in a wide variety of industrial systems and equipment. The selection and application of products remain the responsibility of the equipment manufacturer or end user.

CONTRIVE accepts no responsibility for the way its products are incorporated into the final system design. All systems or equipment designed to incorporate a product manufactured by CONTRIVE must be supplied to the end user with appropriate warnings and instructions as to the safe use and operation of that part.

Any warnings provided by CONTRIVE must be promptly provided to the end user.

CONTRIVE guarantees for two years from the date of manufacture of its product to replace, or, at its option, to repair any product or part thereof (except fuses and with some limitations for tubes and photocells) which is found defective in material or workmanship or which otherwise fails to conform to the description of its sales order. CONTRIVE makes no warranty of merchantability or any other warranty express or implied. CONTRIVE assumes no liability for any personal injury, property damage, losses, or claims arising from misapplication of its products.

CERTIFICATION

- Gas Equipment Directive (2009/142/EC)
- Low Voltage Equipment Directive (2014/35/EC)
- EMC Directive (2014/30/EC)

IN CONJUNCTION WITH:

EN298 –EN746-2 – EN60730-1 – EN13611

- EU type certification
CE 0063CS1560
- Eurasian Customs Union
MEETS TECHNICAL SPECIFICATIONS OF
RUSSIAN FEDERATION, BELARUS AND KAZAKHSTAN

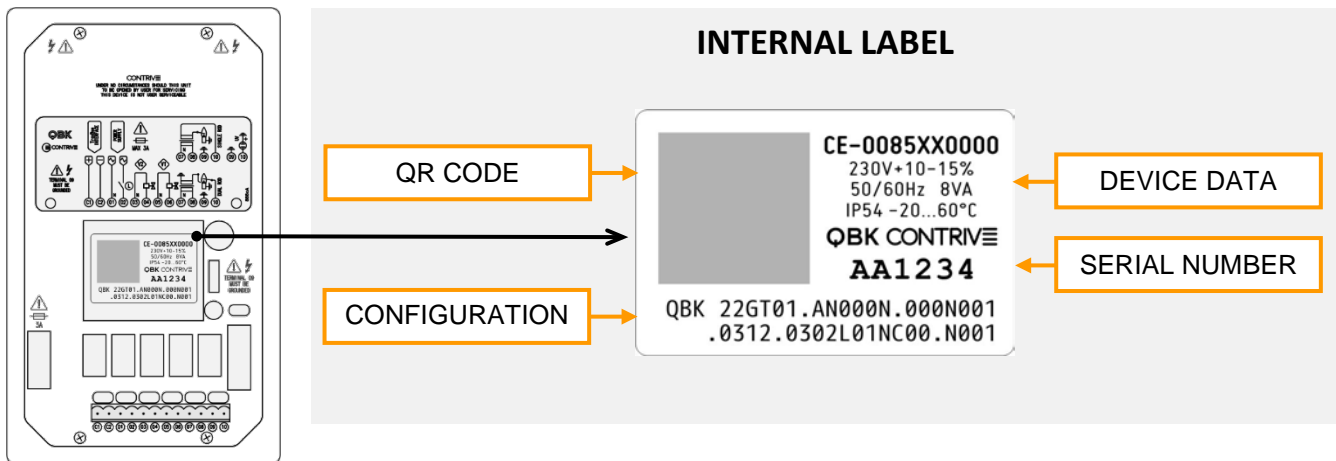

Please perform the following tasks after receiving the product:

- Inspect the unit for damage. If the product appears damaged upon receipt, contact the shipper immediately.
- Verify receipt of the correct power supply and process inputs voltage, by checking the label.
- If you have received the wrong model or the device does not function properly, contact your supplier.

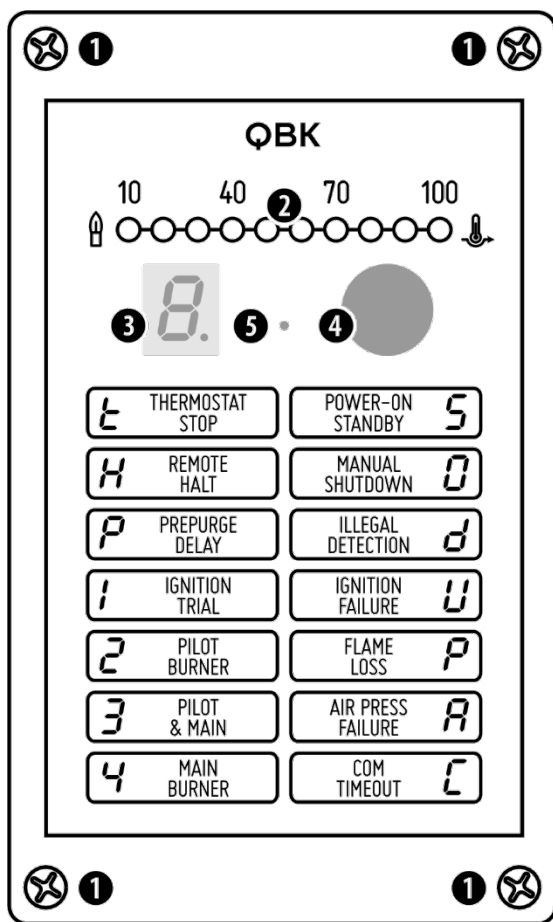

FRONT PANEL

- | | |
|-----------------------------|----------|
| FITTING SCREWS | 1 |
| FLAME SIGNAL BARGRAPH – RED | 2 |
| STATUS DISPLAY | 3 |
| RESET / SHUTOFF BUTTON | 4 |
| COM INDICATOR – YELLOW | 5 |

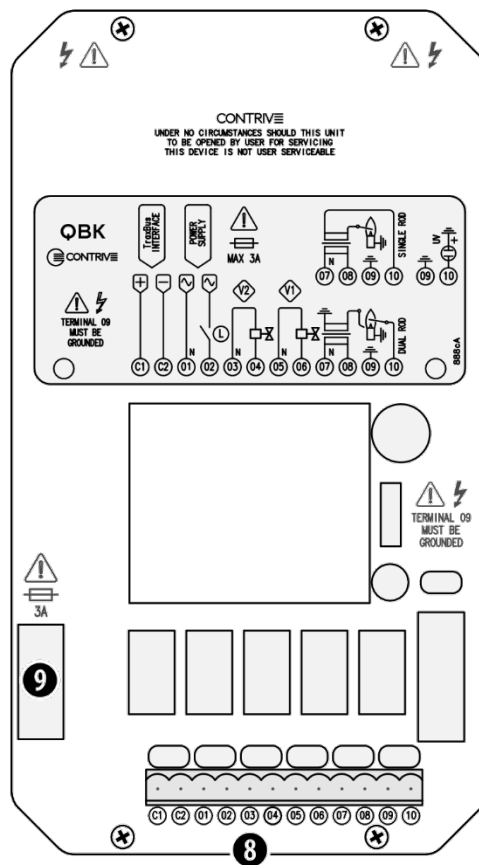

INTERNAL

- | | |
|----------|--------------------------------|
| 8 | MAIN TERMINAL BOARD |
| 9 | POWER SUPPLY FUSE ¹ |
- ¹ ULTIMATE PROTECTION AGAINST DANGEROUS CONDITIONS BY MEANS OF INTERNAL, NON REPLACEABLE 5A SAFETY FUSE

WIRING DIAGRAM

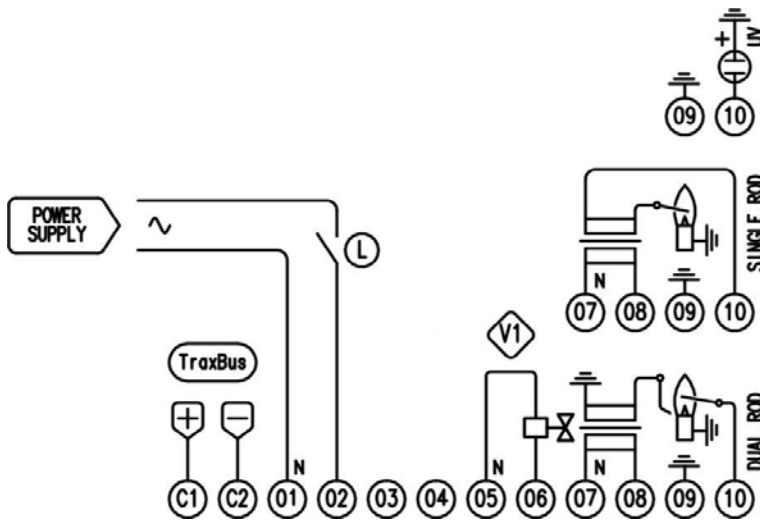

L	EXTERNAL LIMITS	
V1	FUEL VALVE	
C1	COM INTERFACE – POSITIVE	+
C2	COM INTERFACE – NEGATIVE	-
01	POWER SUPPLY – NEUTRAL	N
02	POWER SUPPLY – PHASE	
03	-	N
04	-	
05	FUEL VALVE – NEUTRAL	N
06	FUEL VALVE – PHASE	V1
07	IGNITION TRANSFORMER – NEUTRAL	N
08	IGNITION TRANSFORMER – PHASE	
09	GROUND	
10	FLAME DETECTOR INPUT	ROD UV

USE POWER, SIGNAL AND CONTROL CABLE SUITABLE FOR THE TYPE OF OPERATION AND COMPLYING WITH ALL REGULATIONS DO NOT ROUTE CONNECTIONS TOGETHER WITH FREQUENCY CONVERTER CABLES OR CABLES EMITTING STRONG FIELDS PROVIDE RELIABLE CONNECTION TO PE (PROTECTION EARTH) AND BURNER FRAME, RECOMMENDED WIRE GAUGE > 4 mm² ALL ELECTRONIC SYSTEMS MUST BE SUPPLIED BY A DEDICATED TRANSFORMER IN A TN-S EARTHING SYSTEM

USE UNSCREENED HIGH-VOLTAGE CABLE FOR IGNITION AND IONIZATION ROD LINES, LAYING CABLES INDIVIDUALLY, AVOIDING METAL CONDUITS. KEEP HIGH VOLTAGE IGNITION CABLES AS SHORT AS POSSIBLE, AVOIDING LOOPS AND KEEP ALL OTHER CABLES, ESPECIALLY THOSE OF UV SCANNER OR IONIZATION ROD, AS FAR APART AS POSSIBLE

FUEL VALVE AND IGNITION TRANSFORMER OUTPUTS ARE PROTECTED BY INTERNAL FUSE, THIS FUSE MUST BE REPLACED ONLY WITH SAME TYPE AND VALUE COMPONENT: 3A QUICK-ACTING 5x20mm

COM INDICATOR

Once a valid command is received through the communication line this indicator [5] will blink yellow.

This indicator will blink once at power-on, during self-diagnosis.

A failure to internal supervision logic occurred when this indicator remains permanently on.

Remove power supply and restart. If the unit still inoperative send it back to factory for servicing.

STATUS DISPLAY

The STATUS DISPLAY [3] gives, at any time, a clear indication about the working conditions of both the burner and the equipment, making it easier to detect any failure occurring in the system or the device.

LOCKOUTS



STANDBY

WAITING FOR RESET WHEN PROGRAMMED FOR STANDBY MODE AT POWER-ON.



FLAME SIMULATION

FLAME DETECTION DURING PREPURGE OR POSTPURGE (AFTER POSTCOMBUSTION).



RESET / COMMAND ERROR

ILLEGAL REMOTE COMMAND OR TOO MANY RESETS (MORE THAN 5 WITHIN 15 MIN).



IGNITION FAILURE

NO FLAME DETECTED AT THE END OF 1ST SAFETY TIME (IGNITION TRIAL).



FLAME FAILURE

FLAME QUENCHING DURING NORMAL BURNER OPERATION.



COMMUNICATION TIMEOUT

MISSING COMMANDS FROM SUPERVISOR OR EXPANSION BOARD FAILURE.

CYCLE



MANUAL SHUTDOWN

UNIT HAS BEEN PUT OUT OF SERVICE FROM PUSH BUTTON. PUSH AGAIN TO RESTORE.



REMOTE SHUTDOWN

BURNER HAS BEEN TURNED OFF BY REMOTE CONTROL THROUGH FIELDBUS.



PREPURGE

PURGE OF COMBUSTION CHAMBER OR MIN TIME FOR ILLEGAL FLAME PROVING.



IGNITION

1ST SAFETY TIME. BURNER IGNITION TRIAL WITH PILOT FUEL VALVE OPEN.



BURNER ON

PILOT FUEL VALVE IS ON, OPERATING POSITION FOR SINGLE STAGE BURNERS.



POSTCOMBUSTION

WAITING FOR FLAME QUENCHING AFTER LOCKOUT OR SHUTDOWN REQUEST.



POSTPURGE

PURGE OF COMBUSTION CHAMBER, SHOWN TOGETHER WITH ASSOCIATED CODE.

FAILURES



IGNITION OUTPUT FAILURE

IGNITION DEVICE OUTPUT REMAINS INACTIVE.



FUEL VALVE OUTPUT FAILURE

1ST STAGE (PILOT) FUEL VALVE OUTPUT REMAINS INACTIVE.



OUTPUT RELAYS FAILURE ¹

SHORT CIRCUIT ON OUTPUT RELAY CONTACT LOADS DISCONNECTED BY SAFETY RELAY.



UNDERVOLTAGE

POWER SUPPLY VOLTAGE TOO LOW SYSTEM REMAINS ACTIVE.



OVERVOLTAGE

POWER SUPPLY VOLTAGE TOO HIGH FUSE INTENTIONALLY BROKEN AFTER 5".



MASTER SAFETY RELAY FAILURE ¹

SHORT CIRCUIT ON SAFETY RELAY CONTACT. OUTPUTS RELEASED.



PROGRAM ERROR

WRONG PROGRAM SEQUENCE. UNSAFE OPERATION STOPPED.



MEMORY ERROR

DATA CORRUPTION. CONFIGURATION ERROR.



TIMEBASE ERROR

MISMATCH BETWEEN 1ST AND 2ND INTERNAL TIMEBASE GENERATORS.



SYSTEM ERROR

MICROPROCESSOR IS NOT OPERATING PROPERLY.



FLAME INPUT FAILURE

FLAME SENSOR REVERSED POLARITY OR UNRELIABLE FLAME AMPLIFIER.



RESET FAILURE

PUSH BUTTON OR REMOTE RESET ACTIVE FOR LONG TIME (MORE THAN 10 SECONDS).

¹ A PERMANENT FAILURE TO THE RELAY CONTACT MAY CAUSE THE MAIN FUSE TO BLOWN, AS A SAFETY MEASURE TO PREVENT DANGEROUS CONDITIONS. IN SUCH CASE THE UNIT MUST BE RETURNED TO FACTORY FOR SERVICING.

WARNINGS



SELF-TEST

VERIFICATION AND INITIALIZATION OF SYSTEM COMPONENTS AT POWER-ON.



CONFIGURATION

UNIT IN CONFIGURATION MODE THROUGH COMMUNICATION LINK.

FLAME SIGNAL BARGRAPH

The flame signal strength detected by the sensor connected at terminal 10 is reported by means of 10 led bargraph. Full scale, 100% is corresponding to a flame signal of 30 μA approx. To improve readability, the amplifier provides similar signals for both electrodes and UV scanners. One of the first four indicators blinks when flame is detected but the signal is below the sensitivity threshold set by configuration parameters 404 (1 to 9 μA).

PARAMETERS

GENERAL SETTINGS

001	POWER SUPPLY VOLTAGE	230 Vac	2
		115 Vac	1
003	BURNER TYPE	GAS	6
		OIL	0

BEHAVIOUR AT POWER ON – LOCKOUT

101	START-UP MODE	AUTOSTART	A
		STANDBY	S

BEHAVIOUR DURING SHUTDOWN

201	MINIMUM BURNER PAUSE TIME	0" ...	000
		DEFAULT 0"	250

ALL OUTPUTS SWITCHED OFF WHILE IN MANUAL SHUTDOWN

BEHAVIOUR DURING PREPURGE

303	PREPURGE (WAITING) TIME	0" ...	000
		DEFAULT 1"	250

BEHAVIOUR DURING IGNITION

401	PRE-IGNITION TIME ¹	0,5"	
402	FIRST SAFETY TIME	2" ...	02
		DEFAULT 3"	25
403	BURNER STARTUP ATTEMPTS	1	1
		2	2
		3	3
		4	4
404	PILOT BURNER FLAME SENSITIVITY	1 μA ...	1
		USED ALSO FOR DETECTION IN PREPURGE	9

BEHAVIOR DURING OPERATION

501	PILOT BURNER PROVING PERIOD	1" ...	01
		DEFAULT 3"	25
504	FLAME FAILURE	LOCKOUT	L
		RECYCLE	C
		IGNITION RESTORATION	K
505	FLAME FAILURE RESPONSE TIME	1" ...	01
		DEFAULT 1"	12
508	MINIMUM COMBUSTION TIME	0" ...	00
		... 25"	25
509	ALLOWED POST-COMBUSTION TIME ¹	< 20"	

BEHAVIOR DURING POSTPURGE

602	POSTPURGE (WAITING) TIME	0" ...	000
		DEFAULT 1"	250

COMMUNICATION SETTINGS

701	ZONE (SEGMENT)	0 ... 9 a ... Z	
702	UNIT (NODE)	0 ... 9 a ... Z	
703	BAUD RATE	4800	
		9600	
		19200	
		38400	
		57600 ³	
		115200 ³	
704	TIMEOUT ²	DISABLED	
		1" ...	
	DEFAULT DISALED	... 50"	

- ¹ NON-CONFIGURABLE PARAMETER
- ² INACTIVE WHEN THE BURNER IS OFF
- ³ TraxBus MAY NOT WORK

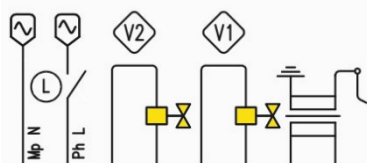

001 – POWER SUPPLY VOLTAGE

Power supply voltage for this burner control device and loads (fuel valves and ignition transformer) wired at terminal 01 and 02. Short circuit and overload protection by internal fuse. Optional safety interlock limits could be wired on the main supply phase.

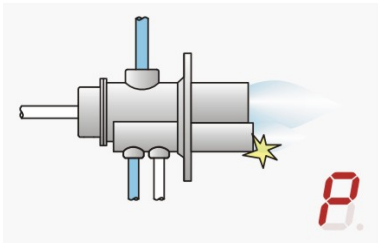

003 – BURNER TYPE

Selecting OIL type burner, the ignition device is switched on during the prepurge to allow the detection of fuel leakage that will be ignited, leading to an illegal flame detection. Electrode is not suitable for flame detection in OIL burners. Shared rod configuration for OIL burners may damage the unit.



101 – START-UP MODE

At power-on, once the self-test has been successfully completed, the unit waits in STANDBY mode until a reset operation is performed from push button, input or through a fieldbus remote command. Setting AUTOSTART mode, the cycle starts automatically, unless the units has been turned off while in lockout.

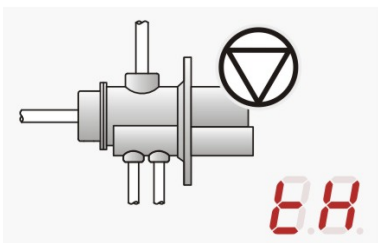

201 – MINIMUM BURNER PAUSE TIME

An immediate restart of the burner after a normal shutdown is prevented by the pause time. The pause time starts when the burner is switched off, after post-combustion and post-purge has been deployed (if any). Any start-up will be ignored until the minimum burner pause time has elapsed.

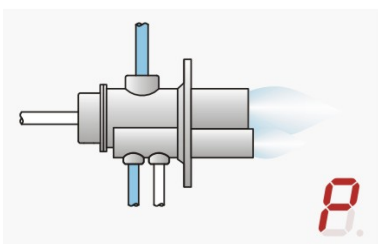

303 – PREPURGE TIME

EN298 § 3.124.1 - § 3.124.2 - § 3.124.3 - § 3.124.4

Set pre-purge time in forced draught burners according to applicable and relevant standards (EN 676). During this time the flame simulation test is carried out. This is a merely waiting time if there is no air control.

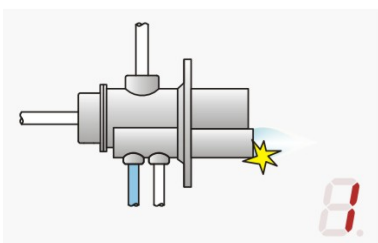

401 – PRE-IGNITION TIME

EN298 § 3.135.3

The ignition transformer is turned on 500 ms before the pilot fuel valve to check the correct operation before supplying the fuel. This is a fixed time and can not be changed.

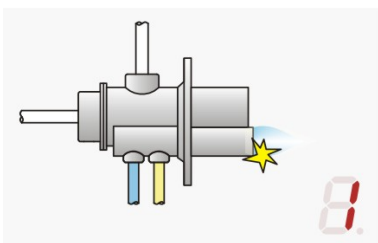

402 – FIRST SAFETY TIME

EN298 § 3.116

Set the correct time following EN 746-2 (or other relevant) requirements:

Natural draught burners $\leq 350 \text{ kW} \rightarrow 10''$ $> 350 \text{ kW} \rightarrow 5''$
 IGNITION POWER $\leq 33\%$ NOMINAL POWER WITH MAXIMUM OF 350 KW
 Forced draught burners $\leq 70 \text{ kW} \rightarrow 5''$ $> 70 \text{ kW} \rightarrow 3''$
 IGNITION POWER $\leq 10\%$ NOMINAL POWER WITH MAXIMUM OF 350 KW

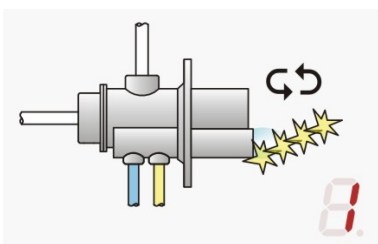

403 – BURNER STARTUP ATTEMPTS

EN746-2 - EN676

When the flame is not detected at the end of startup safety time, it's possible to make up to 4 startup attempts (including the first one), if the safety of the application is not impaired, repeating the cycle from the beginning. A lockout will occur if no flame has formed within programmed attempts.

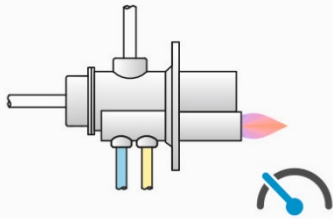

404 – FLAME SENSITIVITY

EN298 § 3.107

The minimum detectable flame signal during the ignition trial and when the first stage burner is running, in the range 1 ... 9 μA (maximum signal is 30 μA). This is the sensitivity used to detect illegal flame during pre-purge and post-purge.

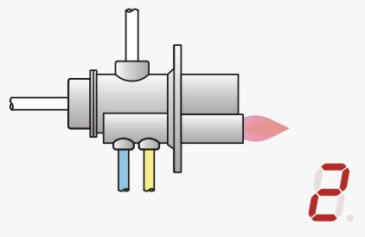

501 – PILOT BURNER PROVING TIME

EN298 § 3.151

This time elapses before to begin the next program step so as to give the pilot burner flame enough time to stabilize. Remains in this condition (until shutdown or lockout).

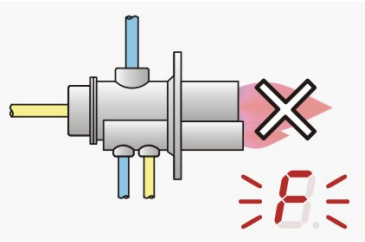

504 – FLAME FAILURE

EN298 § 7.101.2.3

Determines the behavior at flame loss during normal burner operation. For burners with occasionally unstable flame signal a single recycle (including pre-purge) or direct ignition restoration can be attempted. The setting is to be determined on the basis of burner capacity and relevant application standard.

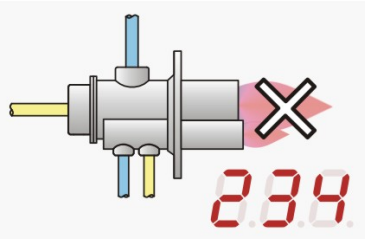

505 – FLAME FAILURE RESPONSE TIME

EN298 § 3.105.1 - § 7.101.3.4.3 - § 7.101.3.7

If the flame fails during operation, gas valves are switched off within this safety time that must be in accordance with relevant application standards (default for EN 298 is 1" and must not exceed 5", including valves closing time for EN 746-2).

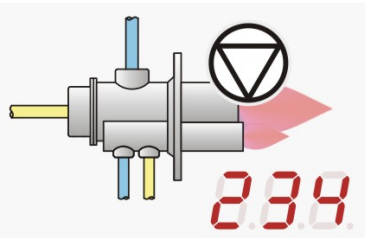

508 – MINIMUM COMBUSTION TIME

An immediate shutdown of the burner, once ignited, is prevented by the minimum combustion time. Time starts once pilot burner has been successfully ignited (after first safety time). Any shutdown from remote fieldbus command will be ignored until minimum combustion time has elapsed.

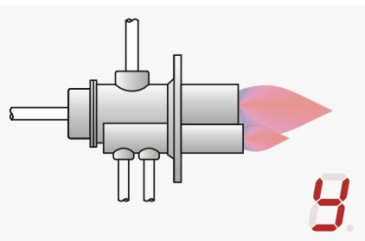

509 – ALLOWED POST-COMBUSTION TIME

Flame signal allowed for 20" once fuel valves has been closed. Lockout occurs when the flame is detected after this post-combustion time. Useful when fuel valves are distant from the burner.

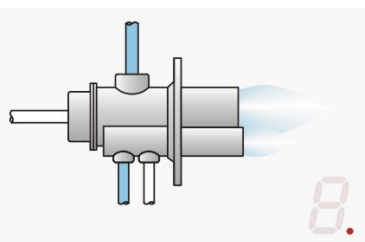

602 – POSTPURGE TIME

EN298 § 3.124.6

Set post-purge time in forced draught burners according to standards (EN 676). The flame simulation test is carried out during this time. This is a merely waiting time if there is no air control.

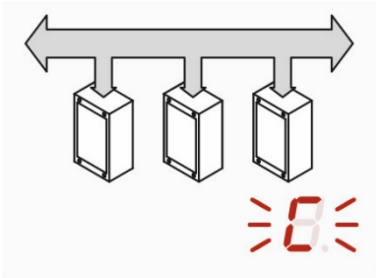

70x – ZONE | UNIT | BAUD RATE | TIMEOUT

701 – ZONE belonging the burner control.

702 – UNIT belonging the burner control.

ALL ALPHANUMERIC (UPPERCASE/LOWERCASE) CHARACTERS ARE VALID IDENTIFIERS

703 – BAUD RATE: 4800, 9600, 19200, 38400

704 – TIMEOUT: remote host must send a valid message within the specified time interval to prevent lockout. Set from 1 to 50 seconds, 0 to disable.

ENCLOSURE

According to European Standard EN60529 a minimum protection degree IP40 must be guaranteed, raised to IP54 for open air application.



ALUMINUM ENCLOSURES MUST BE CONNECTED TO PROTECTIVE EARTH

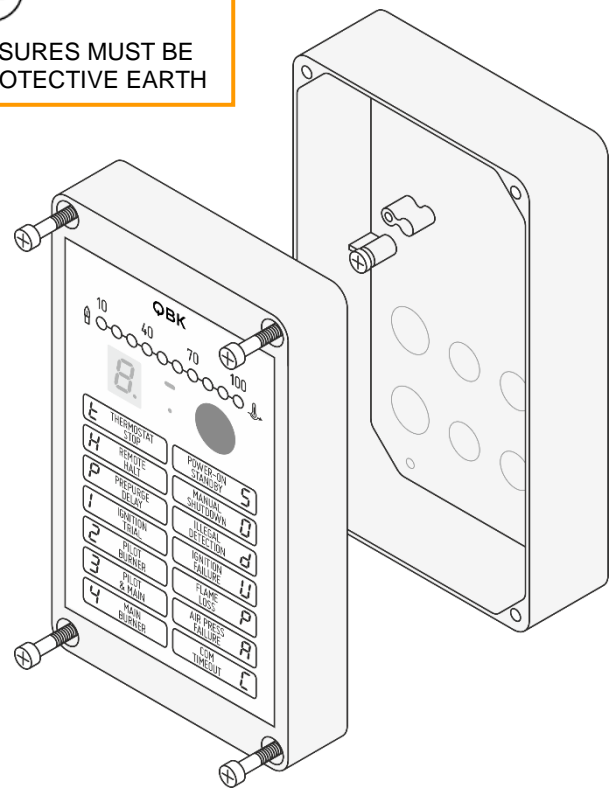
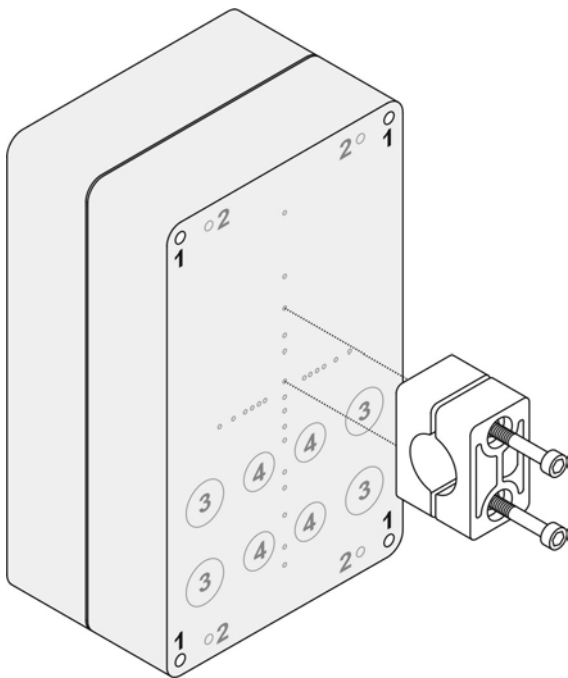

1	EXTERNAL FITTING HOLES (4) 4.2 mm SELF TAPPING OR M5 THREAD FORMING SCREW	106 x 186 mm
2	BREAKABLE FITTING HOLES (4) 4,0 mm DIAMETER	77 x 182 mm
3	BREAKABLE HOLES FOR WIRING (4) SUITABLE FOR PG11 CABLE GLAND	∅ 19,0 mm
4	BREAKABLE HOLES FOR WIRING (4) SUITABLE FOR PG9 CABLE GLANDS	∅ 15,5 mm

QBM - CAST ALUMINUM ALLOY EN AB 46100 IP64
OVERALL DIMENSION: 200 x 120 x 71 mm WEIGHT: ≈ 1150 g
ELECTROSTATIC POLYESTER POWDER COATING RAL9006

QPM - THERMOPLASTIC POLYMER BLEND UL-V0 IP64
OVERALL DIMENSION: 200 x 120 x 71 mm WEIGHT: ≈ 850 g
EXTERNAL FIRE RETARDANT COATING RAL9006

PROGRAM SEQUENCE

A **SELF TEST** IS PERFORMED AT POWER-ON, ONCE SUCCESSFULLY COMPLETED BURNER IS READY TO START.

IF THE UNIT HAS BEEN TURNED OFF WHILE IN **LOCKOUT** OR PARAMETER 101 HAS BEEN SET TO **STANDBY**, IT WILL BE NECESSARY TO PUSH THE BUTTON OR ISSUE A FIELD BUS COMMAND TO EXIT FROM NON-VOLATILE LOCKOUT.

THE BURNER REMAINS IN **SHUTDOWN** UNTIL THE THERMOSTAT 1 IS CLOSED OR A REMOTE RUN COMMAND IS RECEIVED FROM FIELD BUS.

FLAME SIMULATION VERIFIED WHILE IN WAITING OR PREPURGE.

AFTER PRESET **WAITING OR PREPURGE** TIME HAS ELAPSED, IGNITION DEVICE ACTIVATED AND VERIFIED, THEN THE PILOT VALVE IS OPEN.

BURNER PROVING STARTS IF THE FLAME IS DETECTED WITHIN THE **SAFETY TIME**.

IF NO FLAME IS DETECTED WITHIN THE SAFETY TIME, A LOCKOUT OCCURS. DEPENDING ON PARAMETER 403 THE UNIT COULD CARRY OUT UP TO THREE FURTHER **START-UP ATTEMPTS**.

AFTER THE BURNER PROVING THE IGNITION CYCLE IS COMPLETED AND BURNER IS ON.

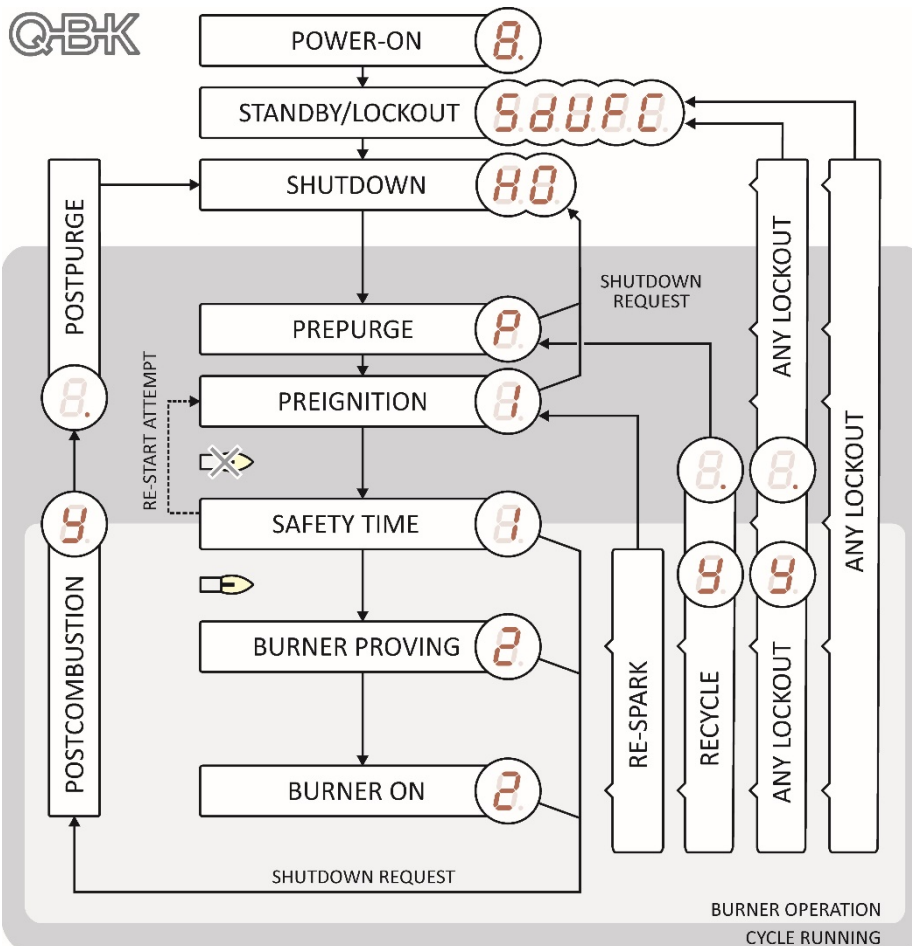

FLAME FAILURE DURING OPERATION LEADS TO LOCKOUT, IGNITION RESTORATION OR RECYCLE (PARAMETER 504).

SHUTDOWN REQUEST (FIELD BUS COMMAND) WILL TURN OFF THE BURNER, WAITING FOR ALLOWED POSTCOMBUSTION AND OPTIONAL POSTPURGE. AN OPTIONAL ADJUSTABLE **MINIMUM COMBUSTION TIME** ENSURES THAT THE BURNER BURNS FOR A DEFINED PERIOD, EVEN IF AN HALT COMMAND IS RECEIVED THROUGH FIELD BUS BEFOREHAND.

RESET

A reset action is supposed to be a clear defined manual action. An automatic reset is not allowed by EN 13611:2015. When manual action is initiated from remote by means of RESET INPUT at terminal 14 or through the FIELD BUS CONTROL, without being within the visible sight of the appliance:

- actual status and relevant information of the process shall be visible to the user,
- QBK limits the maximum number of resets to 5 actions within a span of 15 minutes. Lockout (resettable only from local button) exceeding this limit.

GAS BURNER

The burner is turned ON/OFF together with device power supply or through remote fieldbus command.

A flame simulation test is carried out during pre-purge.

The fuel valve [V1] will be activated only if the ignition device is detected during pre-ignition time.

The fuel valve remains open during the programmed 1st safety time, if a valid flame signal is detected within the safety time the valve is kept open: the burner is ON. If no flame is detected the system will lockout.

In accordance with EN746-2 and EN676, up to 4 ignition attempts are allowed if the safety is not impaired.

Push the front panel button to reset from lockout (will take place at release).

Flame quenching during burner operation will force the system to lockout, recycle or ignition restoration.

To put the burner out of service (manual shutdown) push the front panel button during the operating cycle.

A post-combustion time (max 20 seconds) is allowed after a lockout or shutdown request, followed by post-purge.

UV sensor or ionization rod can be used for flame detection.

It's possible to share a single rod for ignition and flame detection using special ignition transformers.

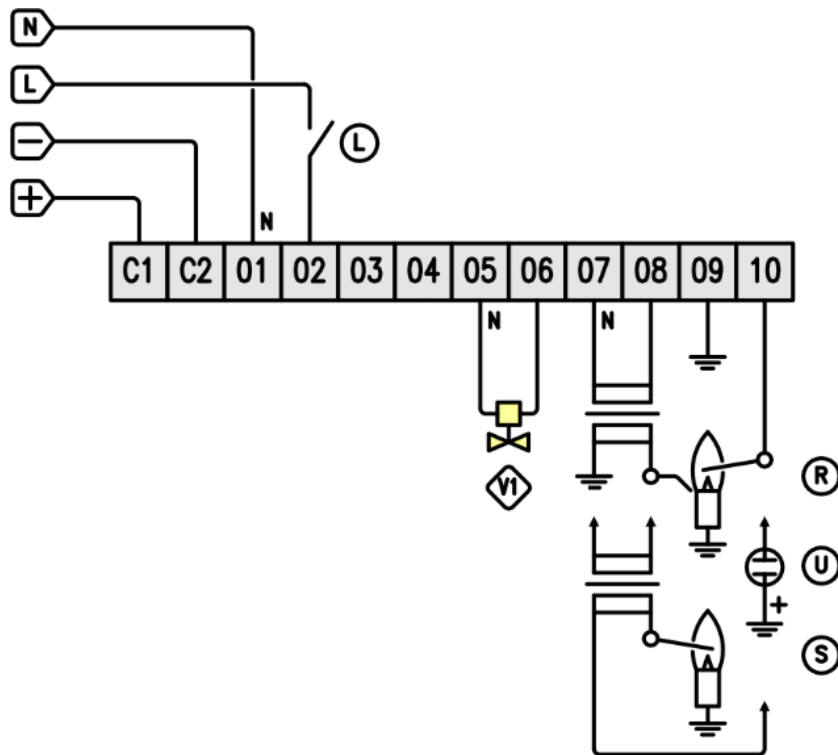

EXTERNAL LIMITS



PILOT GAS VALVE



DUAL ROD CIRCUIT



UV SENSOR



SINGLE ROD CIRCUIT



ALL SAFETY SWITCHES SHOULD BE APPROVED AS LIMIT CONTROLS
THE USE OF ELECTRONIC SWITCHES MAY CAUSE ERRATIC OPERATIONS

OIL BURNER

A typical oil burner application is shown below.

When external thermostat switch ϑ is closed, the blower starts, once the minimum air pressure is reached heating of the oil in the oil preheater will begin.

Once the working temperature is detected, the oil preheater thermostat will provide power supply to device, the pre-purge begins, ignition transformer is activated (long pre-ignition) and flame simulation test is carried out.

The fuel valve [V1] will be activated only if the ignition device is detected during pre-ignition time.

The fuel valve remains open during the programmed 1st safety time, if a valid flame signal is detected within the safety time the valve is kept open: the burner is ON. If no flame is detected the system will lockout.

Push the front panel button to reset from lockout (will take place at release).

Flame quenching during burner operation will force the system to lockout, recycle or ignition restoration.

To put the burner out of service (manual shutdown) push the front panel button during the operating cycle.

A post-combustion time (max 20 seconds) is allowed after a lockout or shutdown request, followed by post-purge.

Only UV sensor can be used for flame detection. Single UV sensor detecting flame.

Ignition restoration is not allowed for burners with a maximum throughput of > 30 kg/h.

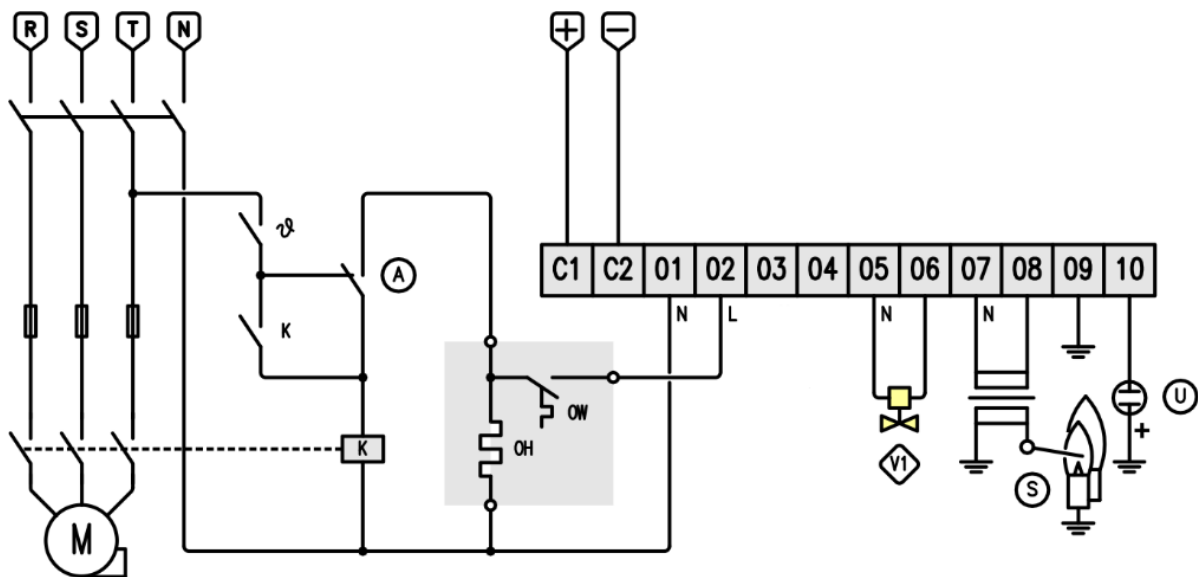

ϑ	THERMOSTAT
K	POWER RELAY
M	BURNER MOTOR
OH	OIL PREHEATER
OW	PREHEATER THERMOSTAT

(A)	LOW AIR PRESSURE SWITCH
(V1)	1 ST STAGE FUEL VALVE
(S)	IGNITION ROD
(U)	UV SENSOR

FIELDBUS REMOTE CONTROL

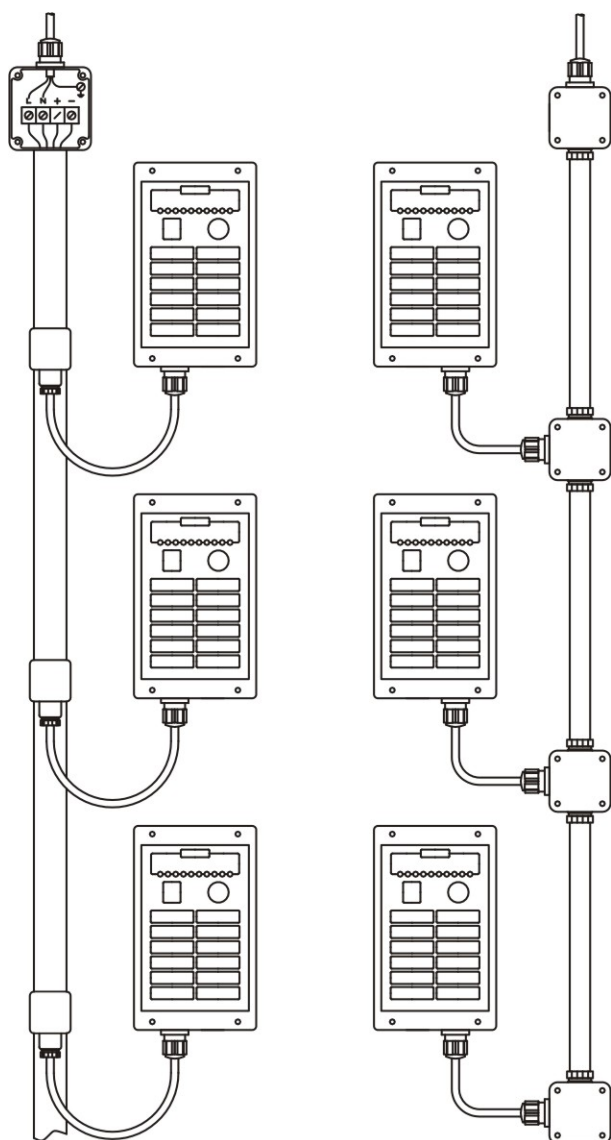

TraxBus using busbars or single wire lines
Ref. to TraxInterface literature for wiring details

Complete remote control and supervision is possible through built-in serial communication interface using proprietary fieldbus, designed for reliable operation in harsh industrial environments with simplified wiring.

Communication protocol could be easily implemented into any programmable controller for great efficiency and low cost. Ready to use gateways are available to convert TraxBus into standard industry fieldbus systems. See below for typical communication time at different baud rates.

Any supervisor takes some time for internal processing, real performance of the fieldbus should be computed adding such delay.

POLLING TIME FOR 1 BURNER

	4800	9600	19200	38400
COMMAND	15 ms	8 ms	4 ms	2 ms
QBK PROCESS	4 ms	4 ms	4 ms	4 ms
ANSWER	15 ms	8 ms	4 ms	2 ms
OVERALL	34 ms	20 ms	12 ms	8 ms

POLLING TIME FOR 10 BURNERS

	4800	9600	19200	38400
COMMAND	150 ms	80 ms	40 ms	20 ms
QBK PROCESS	40 ms	40 ms	40 ms	40 ms
ANSWER	150ms	80 ms	40 ms	20 ms
OVERALL	340 ms	200 ms	120 ms	80 ms

POLLING TIME FOR 100 BURNERS

	4800	9600	19200	38400
COMMAND	1,5 s	800 ms	400 ms	200 ms
QBK PROCESS	0,4 s	400 ms	400 ms	400 ms
ANSWER	1,5 s	800 ms	400 ms	200 ms
OVERALL	3,4 s	2000 ms	1200 ms	800 ms

Messages to/from remote host supervisor must be ASCII characters, 8 bits, no parity, 1 or 2 stop bits.

COMMAND FROM SUPERVISOR TO PERIPHERALS

Commands issued to peripherals within a single string terminated with Carriage Return.

< S N C KK <Cr> < Preamble (from master)
 S Segment, Zone identifier
 N Node, Unit identifier
 C Command
 KK Checksum
 <Cr> Carriage return

STATUS FROM PERIPHERALS TO SUPERVISOR

Peripherals will acknowledge all valid command received from supervisor:

> S N T KK <Cr> > Preamble (to master)
 S Segment, Zone identifier
 N Node, Unit identifier
 T Status
 KK Checksum
 <Cr> Carriage return

S and N can be any alphanumeric character and must match the settings of the peripheral to be addressed.

The special character * (star) can be used like wild card to send broadcast command: a star character instead of S will address all existing nodes, a star character instead of N will address the whole segment, two star characters will address all the connected units. No acknowledge answer sent back after broadcast commands.

CHECKSUM CALCULATION

Commands without valid checksum KK are ignored.
 The answer includes a valid checksum that can be optionally evaluated by supervisor.
 KK is the ASCII figure of the sum of all characters HEX values, including Carriage Return. See example and use only last two characters, ignoring leading ones (if any).

< 0 8 S 04 <Cr>	<	Equals HEX	3C	+
	0	Equals HEX	30	+
	8	Equals HEX	38	+
	S	Equals HEX	53	+
	<Cr>	Equals HEX	0D	=
		ASCII	104	

COMMAND LIST

H	BURNER HALT	SHUTDOWN THE BURNER	
R	BURNER RUN	RESTART THE BURNER FROM SHUTDOWN	
B	UNLOCK	RESET THE BURNER FROM LOCKOUT, MUST BE CONFIRMED	§ 2
Y	UNLOCK CONFIRM	RESET FROM LOCKOUT, CONFIRMATION	
S	STATUS	NO ACTION BUT STATUS REQUEST	
L	FLAME SIGNAL	ACTUAL FLAME CURRENT	

STATUS LIST

S	STOP	BURNER LOCKOUT OR FAILURE	§ 3
0	MANUAL SHUTDOWN	BURNER OUT OF SERVICE (MANUAL SHUTDOWN FROM PUSH BUTTON)	
H	HALT FROM REMOTE	BURNER SHUTDOWN (SWITCHED OFF FROM FIELDBUS)	
P	PREPURGE	PREPURGE IN PROGRESS	
1	IGNITION	BURNER IGNITION TRIAL IN PROGRESS	
2	PILOT ON	PILOT BURNER ON	
Y	POSTCOMBUSTION	WAITING FOR FLAME QUENCHING	
W	POSTPURGE	POSTPURGE IN PROGRESS	
	FLAME SIGNAL	LAST MEASURED SIGNAL STRENGTH 1 ... 26 µA	§ 4

- §2 THE SUPERVISOR MUST SEND A RESET CONFIRMATION WITHIN 25 SECONDS FROM PERIPHERAL ACKNOWLEDGE TO RESET COMMAND. AN UNCONFIRMED RESET COMMAND IS CANCELLED AFTER 25 SECONDS. LOCKOUT WILL BE FORCED TO PREVENT DANGEROUS OPERATION RECEIVING AN ILLEGAL RESET COMMAND (i.e.: CONFIRMATION BEFORE RESET).
- §3 ALL LOCKOUTS AND FAILURES ARE GROUPED WITHIN A SINGLE CODE TO SIMPLIFY THE PARSING. DETAILED INFORMATION AVAILABLE FROM THE FRONT PANEL DISPLAY. ADDITIONAL INFORMATION READING THE LOG FILE STORED INTO THE UNIT.
- §4 SIGNAL STRENGTH RETURNED IN A SINGLE LOWERCASE CHARACTER a TO z:
 - → 0 µA a → 1 µA b...y → 2 ... 25 µA z → 26 µA OR HIGHER

CONFIGURATION

The device is fully configurable through the wired com interface (terminals C1-C2) and specific interface adapter like *TraxInterface*³ or from the infrared port on the front panel and specific interface adapter *Q/beam.USB* using the free software *Q/tool*.
 Smartphone APP available for limited configuration and diagnostic through infrared port.



The unit must be in manual shutdown to enter the configuration environment: display shows a horizontal dash while linked.
 Some parameters are password protected and can only be changed by authorized users or at the factory.

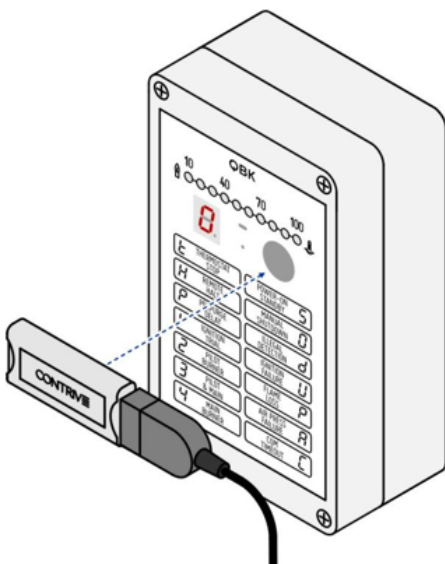

DEFAULT CONFIGURATION

	GENERAL					LCK		SHUT		PURGE			IGNITION			OPERATION						PURGE			
	001	002	003	004	005	101	102	201	202	301	302	303	402	403	404	501	502	503	504	505	506	507	508	601	602
QBM	2	0	G	T	01	A	N	000	N	000	N	001	03	1	2	03	0	2	L	01	N	L	00	N	000
QBM ALUMINIUM QPM PLASTIC	SUPPLY 230 VAC	-	FUEL GAS	-	-	AUTOSTART	AIR OUTPUT OFF	MIN PAUSE TIME 0	-	AIR RUN-UP TIME 0	-	PREPURGE TIME 1	1 ST SAFETY TIME 3	STARTUP ATTEMPTS 1	FLAME SENSITIVITY 2	1 ST PROVING TIME 3	-	-	FLAME FAILURE LOCK	FLAME FAILURE TIME 1	-	-	MIN COMBUSTION TIME 0	-	POSTPURGE 0

TECHNICAL DATA

POWER SUPPLY

VOLTAGE	115 or 230 V +10-15%
FREQUENCY	50/60 Hz
LINE FUSE	3 A QUICK-ACTING - 5x20mm
POWER CONSUMPTION	6 VA MAX
POWER DISSIPATION	4 W MAX

OVERVOLTAGE CATEGORY II PURSUANT TO EN 60730

ENVIRONMENT

OPERATING TEMPERATURE	(-4 ... 140 °F) -20 ... 60 °C
STORAGE TEMPERATURE	(-40 ... 185 °F) -40 ... 85 °C
RELATIVE HUMIDITY	NO CONDENSATION ALLOWED
WEIGHT	≈ 1180 g ALUMINIUM ≈ 850 g PLASTIC
PROTECTION CLASS	IP64 NEMA3
MOUNTING POSITION	ANY

THIS UNIT IS NOT INTENDED FOR EXPLOSIVE OR CORROSIVE ENVIRONMENTS

OUTPUTS

MAX RATED VOLTAGE	250 Vac
MAX SWITCHING VOLTAGE	440 Vac
MAX LOAD (PER OUTPUT)	2 A cosφ=0,7

FLAME DETECTION

MINIMUM IONIZATION CURRENT	> 1 μA
CURRENT LIMITATION	< 1 mA
SIGNAL DISPLAY	0... 100 % 0...30 μA
DETECTOR LINE LENGTH	< 30 m
SINGLE ROD LINE LENGTH	< 2 m
DETECTOR VOLTAGE	250 Vac
DETECTOR INSULATION	> 50 MΩ
UV SENSOR	(NON PERMANENT OPERATION) UV4SH

TRAXBUS COMMUNICATION INTERFACE

VOLTAGE	30 Vdc MAX
BAUD RATE	4800, 9600, 19200, 38400, (57600, 115200)

EC TYPE EXAMINATION - NOTE

Since EN 298 does not describe all functions of QBK – implemented to manage all possible industrial scenarios – the operator is responsible for ensuring that parameters and functions are appropriate for the application. Certification applies only for options and values allowed by EN-298.



CONTRIVE S.r.l. I-24040 SUISIO (Bergamo) via Enrico Fermi 18

ANY ILLUSTRATIONS, PHOTOGRAPHS, OR EXAMPLES USED IN THIS MANUAL ARE PROVIDED AS EXAMPLES ONLY AND MAY NOT APPLY TO ALL PRODUCTS TO WHICH THIS MANUAL IS APPLICABLE. THE PRODUCTS AND SPECIFICATIONS DESCRIBED IN THIS MANUAL OR THE CONTENT AND PRESENTATION OF THE MANUAL MAY BE CHANGED WITHOUT NOTICE TO IMPROVE THE PRODUCT AND/OR THE MANUAL. PRODUCT NAMES, CORPORATE NAMES, OR TITLES USED WITHIN THIS DOCUMENT MAY BE TRADEMARKS OR REGISTERED TRADEMARKS OF OTHER COMPANIES, AND ARE MENTIONED ONLY IN AN EXPLANATORY MANNER TO THE READERS' BENEFIT, AND WITHOUT INTENTION TO INFRINGE. WHILE EVERY EFFORT HAS BEEN MADE TO MAKE SURE THE INFORMATION IN THIS DOCUMENT IS CORRECT, CONTRIVE CAN NOT BE LIABLE FOR ANY DAMAGES WHATSOEVER FOR LOSS RELATING TO THIS DOCUMENT.

© COPYRIGHT 2016 CONTRIVE SRL ITALY. ALL RIGHT RESERVED.